

# !WARNING!

---

**H2O Audio stands behind our products.**

Failure to follow our instructions could destroy your iPod and will void the Warranty. If you have any concerns, or experience any difficulties with your H2O Audio product, we are here to help you, so please contact us directly. We can be reached at:

**1.800.708.6080 or 858.623.0339**

**support@h2oaudio.com**

**www.h2oaudio.com**



**Please take a moment and visit  
[www.h2oaudio.com](http://www.h2oaudio.com)**

For updated Instruction Manuals,  
Product Registration and to  
complete your warranty.



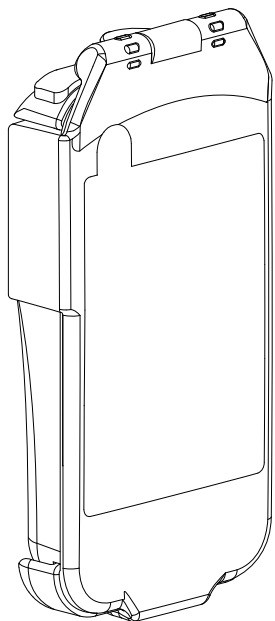

iFR Case for the  
Apple iPhone  
Printed Instructions



Before using this system, please be sure to read, understand, and follow the instruction of this manual.

## 2. Case Features

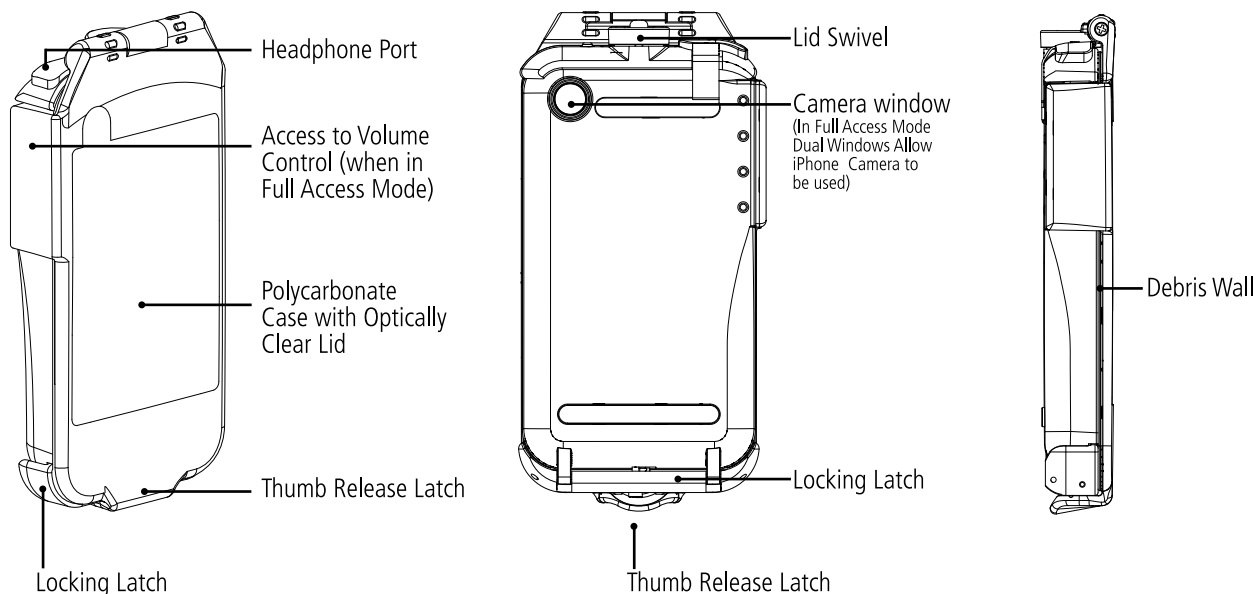

## 3. Introduction

The H2O Audio iFR Case is designed to protect the Apple iPhone from impact and abuse during most sport activities.

The case features the Locking Latch System which keeps the iPhone secure during operation or storage. The H2O Audio case allows for functional control of the iPhone when in Full Access Mode.

While it provides protection from environmental conditions, there are openings in the case for the stereo jack and exterior controls that make the iPhone susceptible to water. The iFR is Not Waterproof, **Do Not Submerge in Water.**

The iFR Case was designed with active, land based, sports in mind, where impact and environmental resistance are required. Sports like:

- \* Skateboarding
- \* Rock Climbing
- \* Snowboarding
- \* Cycling
- \* Motocross
- \* Skiing
- \* Running
- \* Off Roading
- \* Camping
- \* Mountain Biking
- \* Hiking
- \* BMX

## 4. Sport Armband

The iFR Case for the Apple iPhone comes with a Neoprene Sport Armband suitable for most active land based sports.

The Sport Armband with iFR Case provides maximum protection from most environmental conditions including rain and snow.

**The iFR Case and Sport Armband are Not Waterproof Do Not Submerge in Water.**



## 5. Opening the iFR Case

### Opening the Case

1. The lid is held closed by the Thumb Release Latch at the bottom of the case. Use the Thumb Release Latch to flip the lid open.
2. Rotate latch button counter clockwise towards the unlock icon until button stops and latch releases.
3. Open Locking Latch.

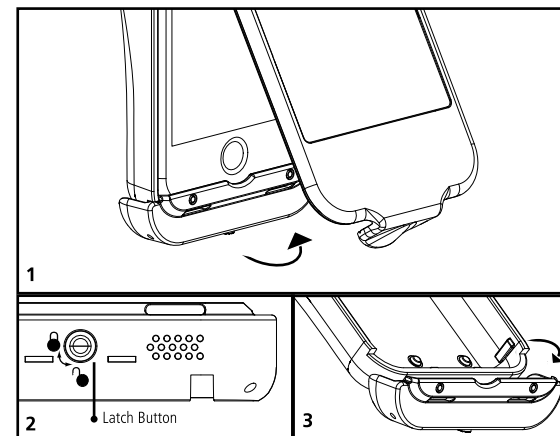

## 6. Installing the iPhone

Once the Locking Latch is open you can install the iPhone into the case. With the screen facing up, and stereo jack oriented towards the top of the case with the volume controls to the side (as shown)

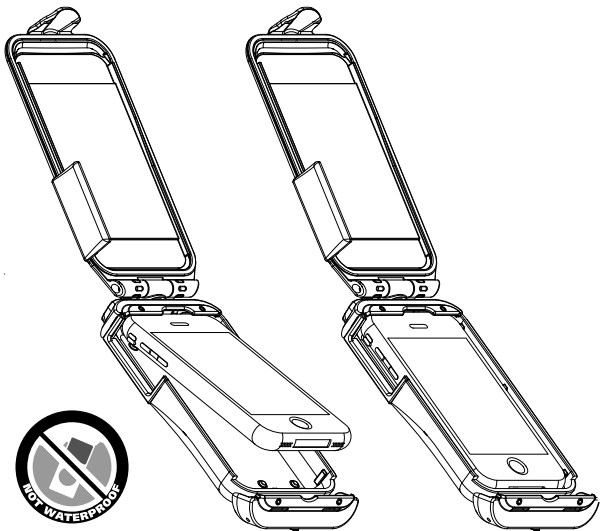

## 7. Closing / Locking the iFR

1. Close the Locking Latch by snapping it back into place.
2. Verify that the Locking Latch is closed and the latch button is in the locked position.
3. Close lid.

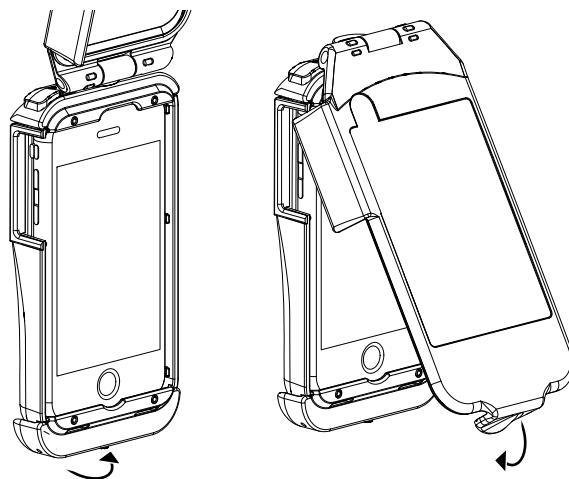

## 8. Access to iPhone

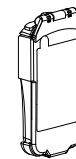

**Protection Mode** - The iFR Case in the Protection Mode provides maximum protection from impacts and most sport activities.



**Full Access Mode** - The iFR Case in the Full Access Mode allows the lid to be stowed away by rotating the lid 180 degrees counter clockwise giving the user full access to all the iPhone controls in or out of the Sport Armband.



Flip



Swivel

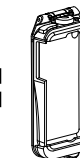

Full Access

## 9. General Storage

For long-term storage, keep out of direct sunlight. Long term UV exposure is not recommended for any materials used in the construction of the case.

**CAUTION:** Do not store case in following environments:

- \* Solvents or other chemical fumes
- \* High humidity
- \* High Ozone
- \* Extreme temperature fluctuations

Storage in such conditions may lead to case damage.

The iFR can be cleaned with soap and warm water. Air dry fully prior to installing the iPhone.

Sport Armband should be hand washed with soap in warm water and allowed to air dry. Do not iron or use bleach.

## 10. Contact Us

Customer Support is available Monday – Friday 9am to 5pm PST.

[h2oaudio.com](http://h2oaudio.com)

P. 1.800.708.6080 or 858.623.0339

F. 858.225.0815

E. [support@h2oaudio.com](mailto:support@h2oaudio.com)

### Copyright Notice:

This owner's manual is copyrighted, all rights reserved. It may not, in whole or in part, be copied, photocopied, reproduced, translated, or formed into any electronic format without prior consent in writing. H2O Audio is a registered trademark of H2O Audio, Inc. Apple and iPod are registered trademarks of Apple Computer Inc. H2O Audio products are protected by Patents 6396769, 6614722, 6954405 Others Pending.

## 11. General Use Notice

READ THIS MANUAL CAREFULLY. IF YOU HAVE ANY QUESTIONS PLEASE CONTACT H2O AUDIO CUSTOMER SUPPORT PRIOR TO USE.

IMPROPER USE OF THIS SYSTEM MAY CAUSE THE USER TO MAKE MISTAKES OR DECISIONS THAT MAY LEAD TO SERIOUS INJURY OR DEATH.

### IMPORTANT WARNING AND DISCLOSURE:

IT CAN BE POTENTIALLY DANGEROUS TO PLAY YOUR HEADPHONES WHILE ENGAGING IN ACTIVITIES THAT REQUIRE YOUR FULL ATTENTION. YOU SHOULD EXERCISE EXTREME CAUTION OR DISCONTINUE USE IN POTENTIALLY HAZARDOUS SITUATIONS. DO NOT USE THE HEADPHONES WHILE DRIVING, CYCLING, OR OPERATING ANY MOTORIZED VEHICLE. IT MAY CREATE A TRAFFIC HAZARD AND IS ILLEGAL IN SOME AREAS.

AVOID USING HEADPHONES AT HIGH VOLUME. HEARING EXPERTS ADVISE AGAINST CONTINUOUSLY LOUD AND EXTENDED PLAY. IF YOU EXPERIENCE RINGING IN YOUR EARS, REDUCE VOLUME OR DISCONTINUE USE.

THE MANUFACTURER DOES NOT WARRANT AND WILL NOT BE HELD RESPONSIBLE IN ANY WAY FOR DAMAGES TO THE iPhone, OR LOSS OF DATA, INCLUDING LOSS OF DATA STORED IN THE iPhone, RESULTING FROM AN EXCESSIVE IMPACT, THUNDER, OR AN ELECTRICITY FAILURE, OR WATER DAMAGE. YOU WILL BE RESPONSIBLE FOR SAFE GUARDING ALL DATA STORED ON YOUR DEVICE.

## 12. Warranty Coverage

H2O Audio guarantees, to the original purchaser only, that the equipment purchased is free of defects in material and/or under normal recreational use for a period of one year (1) from date of consumer purchase from an Authorized Dealer; provided that proper care and maintenance have been performed as prescribed by the owner's guide included with the equipment. Should this product prove to be defective for any reason (other than those listed as limitations below) the product will be serviced or replaced at H2O Audio's sole discretion at no charge (excluding shipping and handling). This warranty shall be void if the registration is not completed and sent to H2O Audio Customer Service within 30 days of purchase. This warranty shall be void if the equipment has been tampered with by anyone not authorized to perform service. The warranty is non-transferable and extends to the original purchaser only and is valid only if the equipment was purchased from an authorized dealer. Warranty does not extend to cover damage from accident, abuse, tampering, lack of maintenance, theft, or loss. Service or modifications by anyone other than an Authorized H2O Audio agent will void the warranty. H2O Audio will not be responsible for recovery or replacement of the product in the event of loss or theft. H2O Audio, its Authorized International Distributors, and Authorized Dealers make no other warranties, either express or implied or orally, or in writing, with respect to any other warranty coverage except those expressly stated within the preceding sentences. H2O Audio will not be held responsible for any agreements orally or in writing with the exception of those expressly included in this warranty statement. The warranty registration card and the terms contained herein supersede all statements contained in any and all owner's guides, instruction cards, or other equipment literature or catalogs. In no event will H2O Audio, its Authorized International Distributors, and Authorized Dealers be held responsible or liable for any personal injuries resulting from the use of the covered equipment, or for any other damages, whether direct, indirect, incidental, or consequential; even if H2O Audio has been advised of such damages.

## 13. Returns

Prior to any return, a Return Authorization (RA) number must be obtained. To receive an RA number, go online to [www.h2oaudio.com/returns.php](http://www.h2oaudio.com/returns.php) and follow the simple instructions on how to return a product. Proof of purchase from an Authorized Dealer will be required. A copy of the original sales receipt and a copy of the owner's portion of the warranty card must accompany all correspondence regarding the equipment covered by this warranty agreement or in direct reference to this warranty.